

**WIZARD DRUM TOOL CO.**

**Wizard<sup>™</sup>**

**DRUM DEHEADER  
OPERATING and SERVICE MANUAL**

Electric, Air and Automatic Air  
Models F, G, H & J

**Bulletin WSD**



# TABLE OF CONTENTS

<b>MODEL DESIGNATION AND FEATURES</b> .....	<b>1</b>
<b>SECTION 1 - GENERAL INFORMATION</b> .....	<b>4</b>
DESCRIPTION .....	4
MODEL DESCRIPTIONS (See Illustrations on Page 1) .....	4
STANDARD POWER SOURCE .....	4
Electric .....	4
Air .....	4
SUPPORT TOWER .....	5
WIZARD COVER LIFTER (Models F and H Only).....	5
WIZARD DEKINKER .....	5
BUNG WRENCH .....	5
<b>SECTION 2 - HOW TO USE YOUR WIZARD</b> .....	<b>6</b>
BEFORE PLACING THE WIZARD ON A DRUM .....	6
PLACING THE WIZARD ON A DRUM .....	6
STARTING THE UNIT .....	6
CUTTING THE DRUM.....	7
Non-Automatic Units .....	7
Automatic Units .....	7
<b>SECTION 3 - REMOVING DRUM LIDS</b> .....	<b>8</b>
CUTTING TECHNIQUE (Models F, G and H Only).....	8
<b>SECTION 4 - CUTTER WHEEL POSITIONING</b> .....	<b>9</b>
LOCATION OF CUTTING POSITION .....	9
HEIGHT OF CUT ADJUSTMENT.....	9
DEPTH OF CUT ADJUSTMENT .....	9
Non-Automatic Units .....	9
Automatic Units .....	9
<b>SECTION 5 - PROPER USE AND CARE</b> .....	<b>10</b>
<b>SECTION 6 -- FACTORY SERVICING</b> .....	<b>10</b>
SHIPPING INSTRUCTIONS.....	10
<b>SECTION 7 -- GENERAL MAINTENANCE AND REPAIR</b> .....	<b>11</b>
FIELD SERVICING.....	11
RETAINING RINGS.....	11
SWIVEL CONNECTOR REMOVAL.....	11
DRIVE CHAIN REMOVAL.....	11
HEAD REMOVAL AND REPLACEMENT.....	11
LUBRICATION .....	11
Electric Motors .....	12
Gear Reducers.....	12
<b>SECTION 8 -- CUTTER WHEEL AND DRIVE ROLLER ADJUSTMENT AND MAINTENANCE</b> .....	<b>12</b>
CUTTER WHEEL OR DRIVE ROLLER REMOVAL AND REPLACEMENT FROM FRONT SHAFT .....	12
CUTTER WHEEL OR DRIVE ROLLER REMOVAL AND REPLACEMENT FROM REAR SHAFT.....	12
<b>SECTION 9 -- SHAFT ASSEMBLIES</b> .....	<b>13</b>
FRONT SHAFT REMOVAL AND REPLACEMENT.....	13
REAR SHAFT REMOVAL AND REPLACEMENT .....	13
<b>SECTION 10 -- TROUBLESHOOTING PROCEDURES</b> .....	<b>15</b>
ELECTRIC MODELS.....	15
Unit does not run (may also give off sparks) .....	15
Unit stalls or does not start.....	15
Unit does not cut drums .....	15
Unit is unstable – wobbles while traveling around drum.....	15
Top drum head cannot be removed (Models F and H).....	15
Unit does not run or cut.....	15

## TABLE OF CONTENTS

AIR MODELS .....	16
Unit does not run.....	16
Unit runs too slow.....	16
Unit does not cut drums ( <i>Manual models</i> ).....	16
Unit does not cut drums ( <i>Automatic models</i> ) .....	16
Top drum head cannot be removed (Models F and H).....	16
Unit does not run or cut.....	16
<b>SECTION 11 -- PARTS LISTS.....</b>	<b>17</b>
ELECTRIC UNITS--MODELS FS, GS, HS AND JS (Sorted by Item Number) .....	19
MANUAL AIR UNITS--MODELS FA, GA, HA AND JA (Sorted by Item Number) .....	22
MANUAL AIR UNITS--MODELS FA, GA, HA AND JA (Sorted by Item Number) (Cont.) .....	23
AUTOMATIC AIR UNITS--MODELS RFA, RGA AND RJA (Sorted by Item Number) .....	25
AUTOMATIC AIR UNITS—MODELS RFA, RGA AND RJA (Sorted by Item Number) (Cont.) .....	26
<b>SECTION 12 -- GLOSSARY .....</b>	<b>28</b>

## Model Designation and Features

Standard Duty WIZARD Drum Openers come in four basic models (F, G, H and J). Each model opens a drum in one of three ways:

- 1) **(OC)** cutting around the outside diameter of the chime (the flat or round rim that fastens the lid to the drum).
- 2) **(IC)** cutting around the inside diameter of the chime.
- 3) **(OS)** cutting around the drum shell below the chime.



**Model FA**

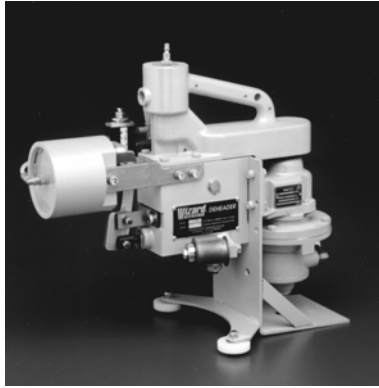

**Model RGA**

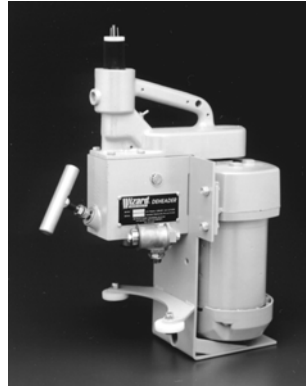

**Model GS**



**Model JA**

All models operate on either air or electricity. Air driven models F, G and J are also available with an air driven regulator to automatically maintain cutter wheel force through an integral air cylinder. The following table shows the eleven currently available variations of the four standard duty basic model groups:

Model No.	Power Source		Auto.	Type	Color	Comments
	Air	Elec.	Air	Of Cut		
FS		X	NO	OC	White	USDA approved for Food industry applications.
FA	X		NO	OC	White	Same as FS. Recommended for washdown areas
RFA	X		YES	OC	White	Same as FS but with cutting pressure automatically maintained.
GS		X	NO	IC	Yellow	For general purpose use. Reuse or scrap drum.
GA	X		NO	IC	Yellow	Same as GS.
RGA	X		YES	IC	Yellow	Same as GS but with cutting pressure automatically maintained.
HS		X	NO	OC	Orange	For outside chime cut on assorted chime sizes.
HA	X		NO	OC	Orange	Same as HS.
JS		X	NO	OS	Blue	Scrap drum.
JA	X		NO	OS	Blue	Same as JS.
RJA	X		YES	OS	Blue	Same as JS but with cutting pressure automatically maintained.

**SERIAL NUMBERS:** Always specify model and serial number (located on housing nameplate) in correspondence and parts requests. This identification is the key to many engineering details applying to your deheader.

		<b>DRUM DEHEADER</b>
<i>Division of Hydro-Thermal Corporation Providing Solutions Worldwide</i>		US PATENTS 2,886,887 AND 3,110,962 CANADIAN PATENTS 612,105 AND 679,868
MODEL NO.	<input type="text"/>	<b>CE CERTIFIED</b>
SERIAL NO.	<input type="text"/>	400 PILOT COURT, WAUKESHA, WI 53188 PHONE: (414) 548-8910 FAX: (414) 548-8915 TOLL FREE 1-800-628-8628
DATE OF MFG.	<input type="text"/>	PART NO. 8125

## GENERAL WARNINGS AND PRECAUTIONS

### ATTENTION

This section must be read thoroughly before operating any equipment supplied by WIZARD Drum Tool Co. Failure to do so may result in damage to equipment and/or severe injury to personnel.

**DANGER**  
**ELECTRICAL**  
**HAZARD**

1. To avoid serious injury or death from electrical shock, make certain the unit is properly grounded.
2. Do not operate any of the electrical units in wet areas.
3. Always use the correct voltage supply as indicated on the unit motor nameplate.
4. Do not use power cord if damaged or frayed.

**DANGER**  
**MECHANICAL**  
**HAZARD**

1. In the event of a temporary power loss, there is the potential that the unit may be restarted automatically if the power switch is left in the "ON" position!
2. Keep all body parts away from the cutter wheel and roller whenever the power is on!
3. If the unit stalls due to blockage between the cutter wheel and the roller, always turn the unit off before attempting to dislodge any debris!
4. The chime of a cut drum may be sharp! Caution should be used when attempting to remove the lid from the drum. It is recommended that leather work gloves be worn when handling cut chimes.
5. Disconnect the power supply (electrical or air) before performing any maintenance on the unit!
6. Do not operate unit on flooring that is not level. The drum may tip over during operation.

The following applies to units purchased for use in non-explosive environments:

**DANGER**  
**EXPLOSIVE**  
**HAZARD**

1. Do not use any of the units to remove the lids off drums which may contain explosive materials.
2. THE UNITS ARE NOT TO BE OPERATED IN EXPLOSIVE ENVIRONMENTS!
3. Extreme care must be taken so that the unit is not operated in any manner to potentially ignite the drum contents and/or any explosive material.

## SECTION 1 - GENERAL INFORMATION

### DESCRIPTION

The WIZARD drum openers are portable, self-propelled and designed to cut the tops and/or bottoms of standard, 30-55 gallon (208 liters) steel drums up to 16 gauge.

All models are available with either an electric or air motor. Models F, G and J are available with an automatic air powered cutting feature. This feature is NOT currently available on the Model H.

WIZARD designs all its drum deheaders for long life, maximum reliability and simplified maintenance. Modular construction permits easy disassembly and adjustment, making parts accessible for repair or replacement with a spare.

### MODEL DESCRIPTIONS (See Illustrations on Page 1)

Model F opener (white) is USDA approved and cuts on the OUTSIDE of the drum chime. Designed specifically for food industry aseptic drums, no part of the Model F touches the drum contents. The outside cut also prevents dirt, paint chips or other debris from falling into the drum and contaminating its contents when opening the drum. The drum deheader's patented, continuous cutting operation and round cutter wheel leave a completely smooth edge, free of slivers or burrs. The drum lid remains secure to protect the drum contents until it is removed with a cover lifter.

The Model G opener (yellow) cuts on the INSIDE of the drum chime and leaves a smooth burr-free edge for safe handling. This versatile model is considered a general purpose opener because opened drums can either be used for utility containers or sold for scrap. This model has a small, 1-1/2" diameter cutter wheel that travels between the chime and bung fittings as it cuts. It is designed to open standard, 30-55 gallon industrial drums of up to 16-gauge steel with either flat or round chimes.

Model H opener (orange) cuts on the OUTSIDE of the chime. Like the Model F, the Model H saves the drum contents from contamination. Its fully adjustable lower chime roller accommodates a wide variety of chime sizes and styles. This model also requires the use of a cover lifter to remove the lid after the drum has been cut.

#### CAUTION

**(For model J). Since the lid becomes completely separated from the drum when cut, the unit has the potential to fall off the drum. Use caution!**

Model J opener (blue) cuts the drum shell BELOW the chime. This model was designed for drum disposal because it removes the entire drum head. Removing both top and bottom

heads of a drum makes it easy to flatten or crush the drum, store it and later sell it for scrap.

### STANDARD POWER SOURCE

#### WARNING

**To avoid serious injury or death from electric shock, make sure the unit is properly grounded and do not use the electric model in wet areas.**

#### Electric

Totally enclosed, fan cooled, permanently lubricated helical gear/needle bearing gear motor. Furnished standard with 1/3 HP, 115 volt single phase, 60 Hz, electric drive and swivel connectors matching standard single grounding plugs. Deheaders are also available in 220VAC 50/60Hz configurations. Satisfactory operation requires a 14ga or larger 3 prong plug properly grounded to earth ground.

#### Air

Variable speed, vane-type air motor and speed reducer. Develops approximately 1/2 HP at 40 psig (275 kPa) (with 25 cfm (0.71 m<sup>3</sup>/min) free air. Best performance is generally achieved with 80-100 PSIG air. Furnished with quick-disconnect coupling for 1/4 inch MINIMUM diameter air line. For long air hose runs we recommend larger 3/8 or 1/2 inch diameter hoses.

Also, for proper operation and maximum service life you MUST install an automatic air line lubricator and filter in the air line feeding the motor.

### **SUPPORT TOWER**

We recommend using a WIZARD Tower to suspend your WIZARD Drum Opener. The tower keeps the opener at working height and also prevents the opener from being dropped or from falling off a wobbly drum.



### **WIZARD COVER LIFTER (Models F and H Only)**

After the WIZARD cuts the chime the lid is ready to be lifted vertically off the drum with a WIZARD Cover Lifter. The cover lifter will remove a properly cut lid quickly and easily. Drum lids may be reused to cover drum.

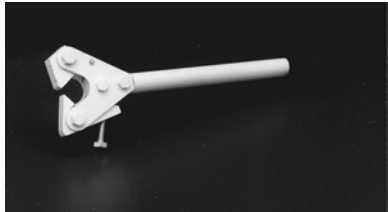

### **WIZARD DEKINKER**

Easily straightens bent or dented chimes so your WIZARD Drum Openers can operate with maximum efficiency. Reseals leaking drums caused by bent chimes.



### **BUNG WRENCH**

All-plug universal wrench easily, safely opens all known styles of American and foreign-made bungs and fittings. Ductile iron and non-ferrous style are available.





## SECTION 2 - HOW TO USE YOUR WIZARD

## PLACING THE WIZARD ON A DRUM

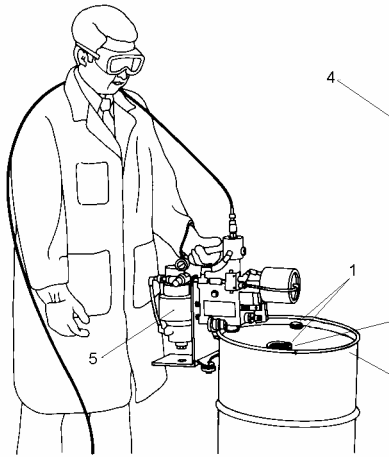

Figure 1

### BEFORE PLACING THE WIZARD ON A DRUM

1. See Figure 1. Remove the plugs from the bung fittings with a WIZARD WRENCH (1 and 2).
2. Hammer down the bungs so they do not block or interfere with either the drive roller or cutter wheel. Note: For Model G with 1-1/2" diameter cutter wheel, only hammer bungs less than 1-1/2" from the drum chime.
3. Straighten any bent chime using a WIZARD Dekinker or hammer them into original contour (3).
4. Make sure the cutter wheel is in the retracted position, away from the drive roller to allow chime clearance.

**Non-Automatic Units:** Turn the adjusting screw handle about six turns counterclockwise.

**Automatic Units:** Turn on supply air to the drum opener and

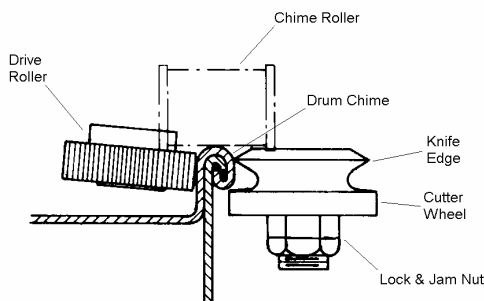
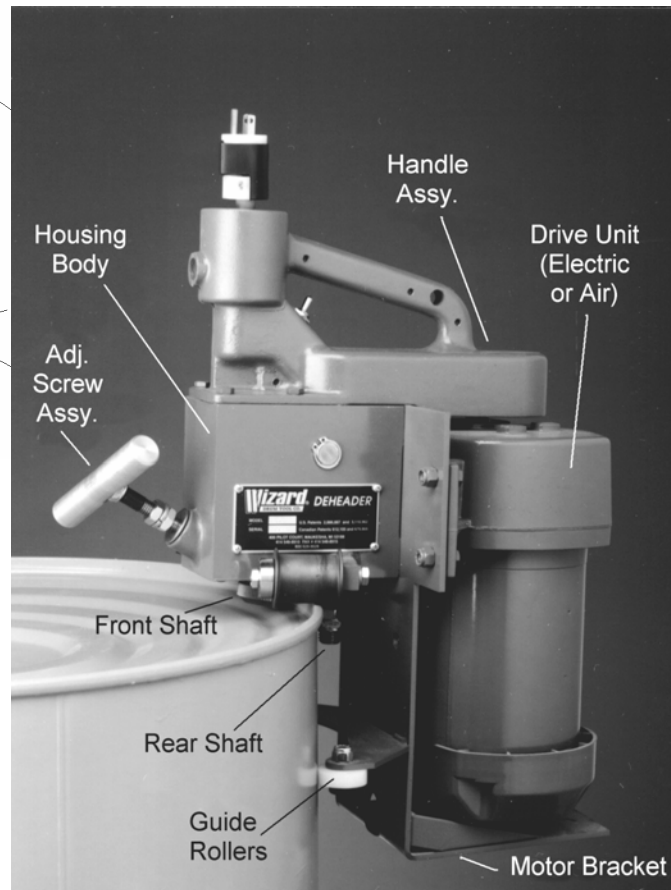

Figure 2

push/pull the plunger button of the air valve.



1. See Figure 2. Place the WIZARD on the drum so the chime rollers ride on the top of the chime. If using an automatic air unit, push/pull the plunger button of the air valve to engage the cutter wheel and skip step 3 below.

### CAUTION

**Dropping the Wizard on the chime may damage the cutter wheel.**

2. Check the unit for proper cutter height position. The cutter height position is factory set; however, you may need to make some minor adjustments. Please refer to section (4) before continuing.
3. Refer to Figure 1. Turn the adjusting screw

handle (4) clockwise until the cutter wheel just touches the chime (3). The cutter wheel must not bite into metal at this point. Excess pressure prevents the electric or air motor (5) from reaching operating speed which may overload motor. The Warranty does not cover motor damage caused by overload.

### STARTING THE UNIT

Many operators place the electric cord or air line over their left shoulder to keep it clear of the WIZARD. This also prevents the cord or line from wrapping itself around the drum as the opener rotates around the drum. Both the electric socket and the air line connector swivel 360° to prevent the line/cord from twisting during rotation.

Electric models have a toggle switch on the side of the handle. Air driven models have a ball valve located on the air line and an air regulator to adjust the rate of travel.

### WARNING

**DO NOT FOLLOW THE WIZARD AROUND THE DRUM.**

Stand in one place and keep the cord or line out of the WIZARD's path. Let the WIZARD make one complete revolution and check for interference from bungs or chime.

## **CUTTING THE DRUM**

### **Non-Automatic Units**

1. Without stopping the drive unit, use **HAND ACTION ONLY** to turn the adjusting screw handle about 1/4 turn clockwise. **DO NOT USE** pipe, rod, or any other leveraging device to raise cutting force. Excessive cutting force may damage the housing body.
2. If you stop the unit for any reason, turn the adjusting screw handle 1/4 turn counterclockwise before you restart. This prevents overloading the drive unit.
3. After each revolution of the WIZARD around the drum, turn the adjusting screw handle another 1/4 turn clockwise. This gradually raises pressure on the cutter wheel so it can cut through the drum or outer chime layer of metal. As the metal splits, it makes a popping or cracking sound. Usually only 2 to 5 revolutions are enough to cut through the metal.
4. After you finish cutting the drum or its chime, turn the adjusting screw handle six turns counterclockwise to retract the cutter wheel. Tilt the WIZARD toward the center of the drum lid and lift the WIZARD off the drum.

### **Automatic Units**

1. Apply air to the opener and push/pull the plunger button of the air valve. With the cutter wheel engaged, the cutting action is automatic as the WIZARD travels around the drum. As the metal splits, it makes a popping or cracking sound. Usually only 2 to 5 revolutions are enough to cut through the metal.
2. After you finish cutting the drum or its chime, push/pull the plunger button of the air valve to disengage the cutter wheel. Tilt the WIZARD toward the center of the drum lid and lift the WIZARD off the drum.

### SECTION 3 - REMOVING DRUM LIDS

Models F and H - The WIZARD Cover Lifter will remove a properly cut lid quickly and easily.

Model G - A soft hit with a long-handled mallet on the top of the drum lid will usually dislodge it and, depending on where it is hit, will either fall to the bottom of the drum or tip sideways so it can easily be removed. Drum lids are sharp so care should be taken.

Model J - After the drum shell is cut the top is free to be lifted off the drum.

#### CUTTING TECHNIQUE (Models F, G and H Only)

The correct way to open a drum is to cut cleanly through only the single outer metal layer of the chime. If the cut is too shallow, it is difficult to remove the head. If the cut is too deep, the cutter wheel life is shortened. With some practice, judging optimum cutting depth is easily done.

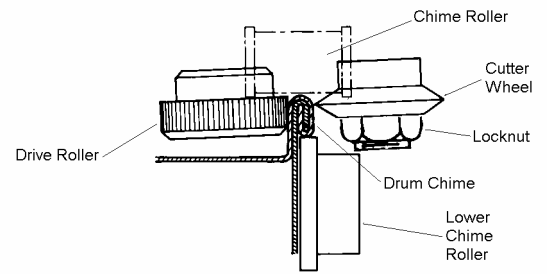

Figure 3C Model H

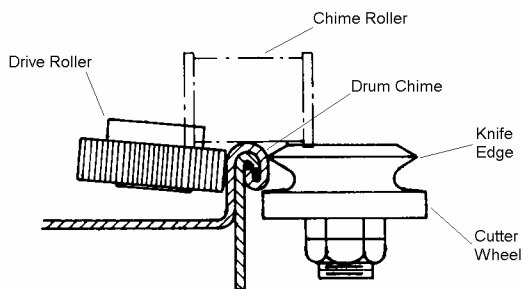

Figure 3A Model F

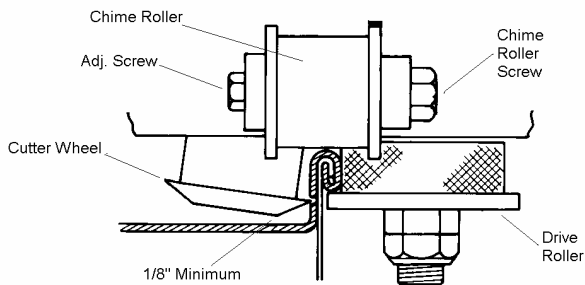

Figure 3B Model G

## SECTION 4 - CUTTER WHEEL POSITIONING

Accurate positioning of the cutter wheel on the drum chime is critical to getting the best performance from your WIZARD Drum Opener. Read Section 4 carefully and check periodically for proper cutter wheel positioning.

### LOCATION OF CUTTING POSITION

Model F - Figure 3A. The cutter wheel shoulder must almost contact the bottom edge of chime when the cutter knife edge just meets the chime. However, the shoulder must not actually touch the chime. The knife edge of the cutter wheel should be from 1/8" to 5/32" (3.1 to 3.9 mm) below the top of the chime.

Model G - Figure 3B. The drive roller flange should just clear the underside of the chime. The cutter wheel should be approximately 1/8" (3.1 mm) or more above the drum lid.

Model H - Figure 3C. The lower chime roller must roll along the underside of the chime. The knife edge of the cutter wheel should be at least 1/8" to 5/32" (3.1 to 3.9 mm) below the top of the chime.

Model J - Figure 3D. The cutter knife edge should contact the drum only far enough under the chime to clear it.

### HEIGHT OF CUT ADJUSTMENT

The chime roller settings control the height of the cut. Because of the variety of drums, you must sometimes change this factory set adjustment. The procedure is the same for all models. Refer to Figures 3A through 3D above, and set the height of the cut as follows:

1. Place the drum opener on the chime as described in Section 2.
2. Using two 9/16" open or box end wrenches, loosen the chime roller screw while holding the adjustment screw (Figure 4).
3. The chime roller axle (shaft) is eccentric to the outside diameter (Figure 4). Turn the adjustment screw while holding the chime roller screw to raise or lower the cutting position.
4. Hold the adjustment screw and tighten the chime roller screw.
5. Repeat steps 2 through 4 on the second chime roller to level the opener on the drum.

#### NOTE

To be sure that the drum opener is sitting level on the drum, check that the bottom edge of the housing body is parallel with the top edge of the drum chime.

6. Engage the cutter wheel either by turning the manual adjusting screw handle (non-automatic units) or by applying air to the drum opener and pressing the top button on the air valve (automatic units). Observe the cutter wheel position and compare it to the appropriate figures.

7. Retract the cutter wheel and repeat the procedure until the cutter wheel position is correct.

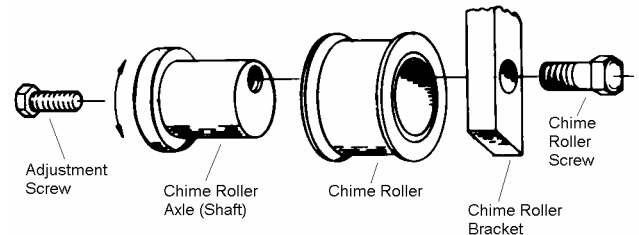

Figure 4

#### NOTE

All of the Part numbers in the following sections refer to the three exploded views and parts lists in Section 11.

### DEPTH OF CUT ADJUSTMENT

Since the cutter wheel wears during normal use, you must occasionally change the factory setting for depth of cut.

#### Non-Automatic Units

1. Loosen the nuts on the adjusting screw handle and back them away from the housing body.
2. Make an experimental cut to determine the cutting depth needed to penetrate ONE layer and stop the machine at this setting.
3. Turn the nuts back against the housing body and tighten them together.

#### Automatic Units

1. Remove the lower linkage guard.
2. Loosen the set screw in the pressure rod boss on the front of the housing body.
3. Turn the pressure rod guide (3111) into the housing body.
4. Make an experimental cut to determine the cutting depth needed to penetrate ONE layer and stop the machine at this setting.
5. Turn the pressure rod guide out of the housing body until it contacts the flat of the pressure rod (3112).
6. Tighten the set screw.

7. Replace the lower linkage guard before operating the unit.

### **SECTION 5 - PROPER USE AND CARE**

With proper use and care your WIZARD Drum Opener will give you long and dependable service.

1. Lubricate the unit properly. Refer to Section 7.
2. Do not drop your drum opener. If unit falls and damage is excessive or unit fails to operate, call for factory assistance.
3. Be certain your electrical connections and air line hookups leading to the drum opener are correct and safe.
4. DO NOT use any kind of levering tool on the manual adjusting screw handle. Excessive force may damage your drum opener.
5. Occasionally wire-brush the drive roller serration's.
6. All of the components of the front and rear shaft are drawn together using a self-locking nut which contains a nylon threaded insert. When properly tightened, all axial play should be removed from each shaft and some drag should be felt in the bearing when rotating the shaft. Check periodically that the front and rear shafts are tight and refer to Section 9 for proper shaft maintenance if they are not. If the shaft tightness requires repeated attention, the self-locking nut is worn and should be replaced.

### **SECTION 6 -- FACTORY SERVICING**

Send units requiring major service to the factory. WIZARD will make a repair estimate and perform the repair only after your authorization is given.

**NOTE: Contact Factory for Return Authorization Before Returning Unit.**

### **SHIPPING INSTRUCTIONS**

When returning openers to the factory:

1. Get return authorization number from factory.
2. Clean all exterior and accessible parts.
3. Fasten an identification tag to your machine. The tag should show your company name and shipping address, and the model and serial number of your unit.

Ship PREPAID to:

**WIZARD Drum Tool Company  
400 Pilot Court  
Waukesha, WI 53188**

**COD shipments are not accepted.**

## SECTION 7 -- GENERAL MAINTENANCE AND REPAIR

WIZARD designs all its drum openers for long life, maximum reliability and simplified maintenance. Modular construction permits easy disassembly and adjustment, making parts easily accessible for repair or replacement with a spare.

### FIELD SERVICING

Light servicing and maintenance is possible with ordinary hand tools. Replacement parts are available from factory stock. Use and experience will determine which parts to keep on hand for routine maintenance, such as cutter wheels or shaft assemblies.

Study the exploded view drawings in Section 11 and note relative positions of the parts before disassembly.

#### NOTE

**Disconnect any electrical or air pressure supply from the drum opener before attempting to conduct any maintenance or repair**

### RETAINING RINGS

The pivot pin (3070) and one end of the rear shafts (3510 and 3512) have snap rings. You can easily remove these with snap ring pliers.

### SWIVEL CONNECTOR REMOVAL

To remove the swivel from your WIZARD Opener, follow these simple steps:

1. Unplug the opener from the power outlet.
2. Remove the four 1/8" socket head capscrews (2144) holding the two handle halves together.

#### NOTE

**It is not necessary to remove the entire handle.**

3. Remove the two hex head capscrews (2106) holding the handle to the housing body from the handle half that is opposite from the power cord. Second half of handle remains attached to housing body. (DO NOT DISTURB THE DRIVE CHAIN.)
4. Disconnect motor leads from power switch and from one swivel connector lead.
5. Disconnect remaining swivel connector lead from power switch and remove swivel connector.
6. To install new swivel, refer to wiring instructions included with replacement swivel.

### DRIVE CHAIN REMOVAL

Remove the drive chain (3190) by following these simple steps:

1. Remove the handle by removing the four hex head capscrews (2106) holding it to the housing body.
2. Open the chain at the connecting link, being careful not to lose the spring clip, and install new chain.

Or as an alternative:

1. Remove lower two nuts and capscrews from motor bracket and loosen or back off the top two nuts and capscrews about halfway to allow motor to tilt to a 30-45 degree angle. With motor tilted, chain becomes slack and can easily be removed from sprockets.
2. Install new replacement chain on smaller motor sprocket first and then on larger driven sprocket.

#### NOTE

**If chain is too loose, remove slack by inserting flat washers or shims between the motor feet and bracket.**

### HEAD REMOVAL AND REPLACEMENT

For convenience and easy handling during maintenance operations, you may want to separate the head assembly from the drive unit and handle assembly.

1. Remove the handle assembly by removing the four hex head capscrews holding it to the housing body.
2. Remove the four capscrews holding the motor to the motor bracket.
3. Remove the four capscrews holding the motor bracket to the housing body.
4. Disengage the larger sprocket (3180) from the chain.

#### NOTE

**During head assembly, make sure to put the chain back on the sprocket before installing the motor bracket. Install the lower screws first when attaching the bracket.**

### LUBRICATION

Periodically lubricate your WIZARD as follows:

1. Remove one side plate from the housing body.
2. Apply a generous amount of light grease to the shaft gears. Use Thermotex EP-1, or equivalent, on all Model G and J

openers. Use Fel-Pro Food Machinery Grease or equivalent on all Model F and H openers.

3. Grease pack bearings any time shaft is disassembled. Repack at any time if grease becomes dry or caked.

### **Electric Motors**

The gearmotor gets a lifetime lubrication at the factory with permanent, heavy fluid gear oil, so it should not be necessary to lubricate the gearmotor.

### **Gear Reducers**

Check the gearbox grease annually. If unit requires additional grease, use EP-O or equivalent. For proper operation and maximum service life, you **MUST** install an automatic air line lubricator and filter in the air line leading up to drum deheader.

## **SECTION 8 -- CUTTER WHEEL AND DRIVE ROLLER ADJUSTMENT AND MAINTENANCE**

All machine tool cutting edges become dull through regular use. Although the WIZARD cutter wheel is made from high-grade hardened tool steel, it will eventually lose its edge after a lot of cutting. If the WIZARD needs more than 7 or 8 revolutions to dehead a drum, the cutter wheel may be dull. If the cutter wheel or drive roller becomes badly worn or chipped replace them as follows:

### **CUTTER WHEEL OR DRIVE ROLLER REMOVAL AND REPLACEMENT FROM FRONT SHAFT**

1. Make sure cutter wheel or drive roller is in the retracted position.
2. Remove one snap ring holding the pivot pin (3070) in place. Remove the pin from the housing body.
3. Drop the front shaft carrier assembly downward and remove it from the housing body.
4. Remove the slotted hex nut & cotter pin from the front shaft.
5. Remove the set screw from the gear.
6. Remove the woodruff key from the shaft and disassemble the carrier assembly. The drive roller or cutter wheel may be difficult to remove because of the tight fit.
7. Install the new drive roller or cutter wheel on the top end of the shaft. Reassemble the carrier assembly, doing each step in reverse order of disassembly.
8. Install the front shaft carrier assembly in the housing body. Insert the pivot pin and attach the snap ring.

### **CUTTER WHEEL OR DRIVE ROLLER REMOVAL AND REPLACEMENT FROM REAR SHAFT.**

1. Remove one side plate from the housing to expose the shaft gears (3100). Block the gears to prevent the shaft (3510 or 3512) from turning.
2. Remove the lock & jam nuts holding the cutter wheel or drive roller in place. Remove the cutter wheel or drive roller from the shaft.
3. Inspect woodruff key and replace if worn.
4. Install the new cutter wheel or drive roller on the shaft and secure it with the lock & jam nuts. Tighten until all vertical play disappears and there is a slight drag on the bearings.
5. Free the gears and install the side plate.

## SECTION 9 -- SHAFT ASSEMBLIES

### FRONT SHAFT REMOVAL AND REPLACEMENT

1. Remove the front shaft carrier assembly and its drive roller or cutter wheel as described in Section 8.
2. Remove slotted hex nut & cotter pin and loosen the set screw holding the shaft gear (3100). Remove the shaft (3499) from the assembly, drawing the shaft downward and through the gear.

#### NOTE

The bearing cups (outer races) are press-fitted and almost never need replacing.

3. Replace any worn parts and assemble the shaft as follows:

#### NOTE

If you remove the bearing cups and there is no press equipment for installation, use a soft hammer to tap the cups into position. When resetting the cups, insert a support in the gear cavity to prevent its deformation under pressure. (See Figure 5.)

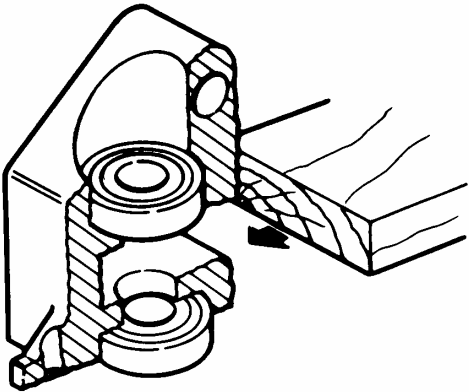

Figure 5

4. Install the drive roller or cutter wheel with its woodruff key (3130) on the bottom of the shaft.
5. Slide the shaft through the lower bearing (3090), gear (3100) and upper bearing (3090). Be sure the gear's woodruff key is in place, but do not tighten the gear setscrew at this point.
6. Install the top slotted hex nut & cotter pin. Tighten until all end play disappears and there is a slight drag on the bearings.
7. Install the front carrier assembly in the housing body. Install the pivot pin (3070) and its snap rings (3120).
8. Align the shaft gears (3100) and tighten the set screw.

### REAR SHAFT REMOVAL AND REPLACEMENT

1. Remove the four hex head capscrews (2106) holding the handle to the housing body. Remove the handle, but do not disconnect the motor leads or air line.
2. Remove one side plate from the housing body and block the shaft gears (3100).
3. Unscrew the lock & jam nuts from the lower end of the rear shaft. Remove the cutter wheel or drive roller and its key from the shaft.

#### NOTE

The cone of the lower bearing is now free to drop out.

4. Remove the lower bearing cone (3090A).

#### NOTE

The bearing cups (outer races) are press-fitted and almost never need replacing.

5. Remove the snap ring (3120) from the upper end of the shaft and remove the sprocket (3180) and its key (3130) from the rear shaft (3510).
6. Remove the spacer (3110) from the shaft on Models FS, FA and RFA and loosen the set screw on the shaft gear (3100).
7. Draw the shaft downward through the upper bearing and shaft gear, out of the housing body.

#### NOTE

The top bearing cone and shaft gear are now free for removal.

8. Replace worn or broken parts. If the bearing cups need replacement, see NOTE and Figure 5 at left. Assemble the rear shaft as follows:
9. Install the snap ring (3120) on the rear shaft.
10. Insert the top woodruff key (3130) in the shaft and install the sprocket gear (3180) on it. Gently tap the sprocket into position using a soft mallet.
11. Install the spacer (3110) on the shaft.
12. Install the bearing (3090) on the shaft.
13. Install the second woodruff key (3130) on the shaft.
14. Position the shaft gear (3100) in the gear cavity.
15. Insert the shaft through the top bearing cup into the gear housing, through the shaft gear (3100), and through the bottom bearing cup. Install the shaft gear over its key (3130), tapping lightly with a soft mallet to seat it.



16. Install the lower bearing (3090).
17. Install the cutter wheel or drive roller and the last woodruff key (3130) on the shaft.
18. Install and tighten the bottom lock & jam nuts. Tighten until all end play disappears and there is a slight drag on the bearings.
19. Align the shaft gears (3100) and tighten the set screws.

## SECTION 10 -- TROUBLESHOOTING PROCEDURES

### ELECTRIC MODELS

Problem	Possible Cause	Remedy (see note below)
<b>Unit does not run (may also give off sparks)</b>	Faulty power connection.	Check replace line cord.
	Swivel connector broken.	Replace swivel connector.
	Power switch broken.	Replace toggle switch.
	Loose electrical connection.	Check wiring inside handle.
<b>Unit stalls or does not start</b>	Excessive pressure on cutter wheel (manual units only).	Back off adjusting screw handle (manual models only).
<b>Unit does not cut drums</b>	Cutter wheel dull or chipped.	Reset position of locknuts on adjusting screw handle to obtain more cutting depth. Replace cutter wheel
	Cutter wheel does not penetrate deep enough to get through layer of metal.	Reset position of locknuts on adjusting screw handle to obtain more cutting depth.
	Not enough cutting passes around drum.	Increase the number of cutting passes.
	Adjusting screw handle bottoms out (manual units only).	Adjust locknuts for greater travel on adjusting handle (manual units only).
	Not enough pressure (force) on cutter wheel.	Tighten adjusting screw handle.
<b>Unit is unstable – wobbles while traveling around drum</b>	Chime rollers out of alignment.	Adjust chime rollers until unit is level.
	Drum chime kinked.	Straighten chime using WIZARD Dekinker.
	Drum shell dented.	Guide unit past dented area.
<b>Top drum head cannot be removed (Models F and H)</b>	Outer metal chime layer not cut completely through.	Tighten cutter wheel adjusting screw (manual units only). Increase the number of cutting passes.
	Cut location too low.	Cut above center of chime.
	Cutter wheel not penetrating metal.	Replace dull or chipped cutter wheel.
	Improper pry tool used to remove lid.	Use WIZARD cover lifter.
<b>Unit does not run or cut</b>	Defective motor.	Replace motor.
	Gears in body housing not meshing.	Adjusting screw out too far – adjust.
	Woodruf key sheared or missing.	Check all shaft parts for Woodruf keys.
	Cutter wheel/drive roller hits bung.	Hammer down bungs for clearance.
	Drive roller worn or dirty.	Replace or clean drive roller serrations with a wire brush.

**NOTE: Contact Factory for Return Authorization Before Returning Unit.**

**Troubleshooting (cont.)**

**AIR MODELS**

<b>Problem</b>	<b>Possible Cause</b>	<b>Remedy (see note below)</b>
<b>Unit does not run</b>	Insufficient air pressure.	Check air supply, compressor and/or regulator.
	Clogged air lines.	Check air connections.
	Air motor frozen or jammed.	Reverse air line to free vanes. Check air line lubricator for oil.
	Faulty throttle/sleeve valve	Replace valve.
<b>Unit runs too slow</b>	Air pressure too low	Increase air pressure.
	Excessive pressure on cutter wheel (manual models only).	Back off adjusting screw handle (manual models only).
<b>Unit does not cut drums (<i>Manual models</i>)</b>	Cutter wheel dull or chipped.	Replace cutter wheel.
	Cutter wheel does not penetrate deep enough to get through layer of metal.	Reset position of locknuts on adjusting screw handle to obtain more cutting depth.
	Not enough cutting passes around the drum.	Increase the number of cutting passes.
	Adjusting screw handle bottoms out.	Adjust locknuts for greater travel on adjusting handle.
	Insufficient pressure (force) on cutter wheel.	Tighten adjusting screw handle.
<b>Unit does not cut drums (<i>Automatic models</i>)</b>	Not enough cutting passes around the drum.	Increase the number of cutting passes.
	Air pressure too low	Increase air pressure.
	Insufficient pressure rod travel to obtain necessary cutter wheel force.	Reset pressure rod guide screw for greater pressure rod travel.
	Loss of air pressure in cylinder.	Replace seals and O-rings in cylinder.
<b>Unit is unstable – wobbles while traveling around drum</b>	Chime rollers out of alignment.	Adjust chime rollers until unit is level.
	Drum chime kinked.	Straighten chime using WIZARD Dekinker.
	Unit running too fast.	Reduce air motor pressure.
	Drum shell dented.	Guide unit past dented area.
<b>Top drum head cannot be removed (Models F and H)</b>	Outer metal chime layer not cut completely through.	Tighten cutter wheel adjusting screw (manual units only. Increase the number of cutting passes.
	Cut location too low.	Cut above center of chime.
	Cutter wheel not penetrating metal.	Replace dull or chipped cutter wheel.
	Improper pry tool used to remove lid.	Use WIZARD cover lifter.
<b>Unit does not run or cut</b>	Defective air motor.	Replace air motor.
	Gears in body housing not meshing.	Adjusting screw out too far – adjust.
	Woodruf key sheared or missing.	Check all shaft parts for Woodruf keys.
	Cutter wheel/drive roller hits bung.	Hammer down bungs for clearance.
	Drive roller worn or dirty.	Replace or clean drive roller serrations with a wire brush.

**NOTE: Contact Factory for Repair Authorization Before Returning Unit.**

**SECTION 11 -- PARTS LISTS**

ELECTRIC UNITS--MODELS FS, GS, HS AND JS

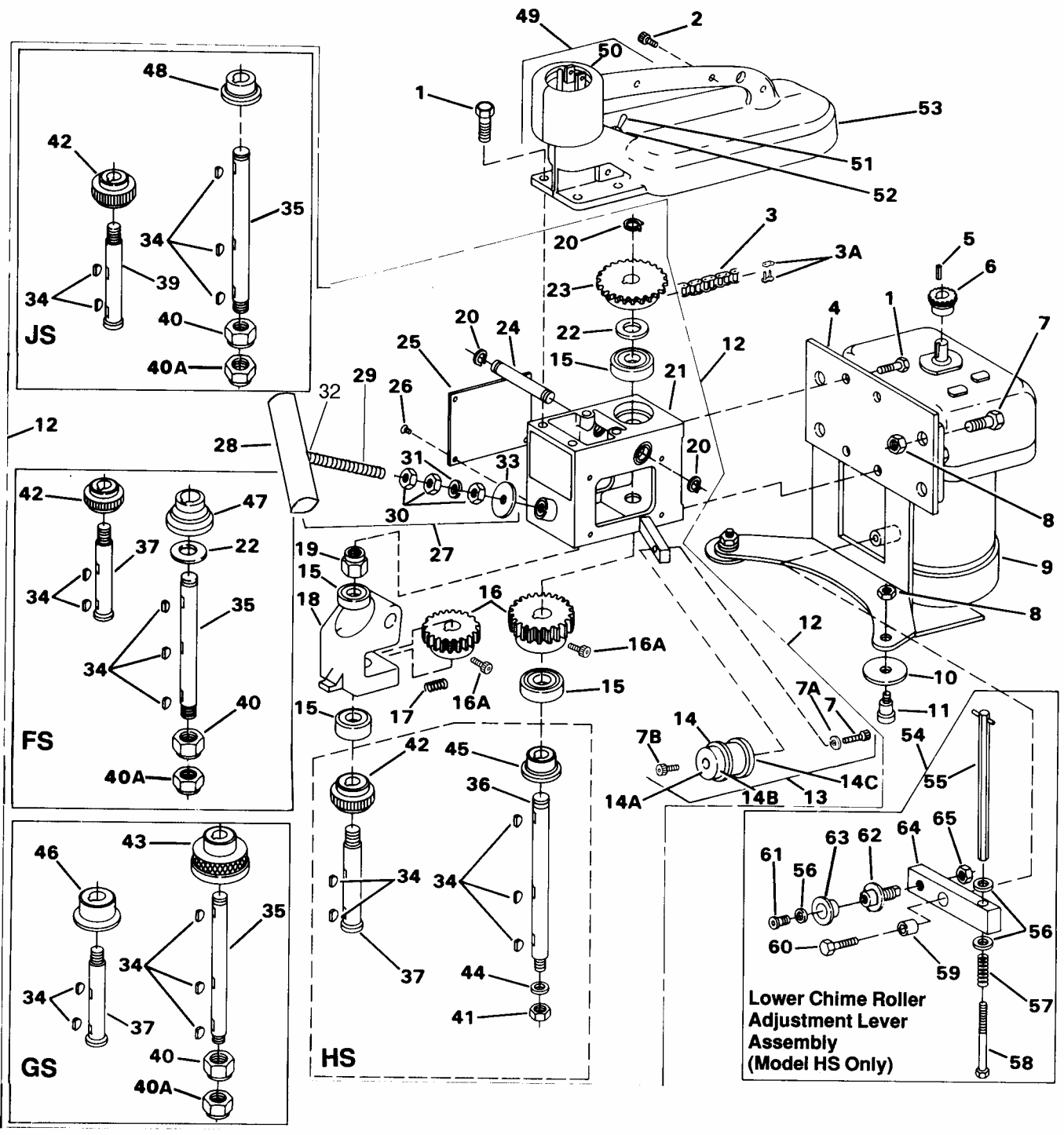

**ELECTRIC UNITS--MODELS FS, GS, HS AND JS (Sorted by Item Number)**

Item	Part No.	Description	Item	Part No.	Description
1	2106	Capscrew, Hex Head	49	3722	Handle Assembly
2	2144	Capscrew, Socket Head	<b>Note: Item 49 includes Items 50 through 53</b>		
3	3190	Chain, 1.33ST 31 Links	50	3042	Swivel Connector
3A	3340	Link, Connecting	51	3030	Motor Switch
4	3563	Bracket, Motor, Model H	52	3038 NA	ON/OFF Plate
	3568	Bracket, Motor Models F, G & J	53	3023	Handle
5	3360	Key, Woodruff, Motor Shaft	<b>Model FS Inset</b>		
6	3172	Sprocket, Drive	22	3110	Spacer, Rear Shaft, 1/2" Flat
7	2110	Capscrew, Hex Head	34	3130	Key, Woodruff
7A	5606	Washer, Lock	35	3510	Shaft, Rear
7B	2112	Capscrew, Hex Head	37	3499	Shaft, Front
8	5238	Nut, Aviation	40	5371	Nut, Lock
9	3019	Motor, Gearmotor, Electric	40A	5372	Nut, Jam
10	3200	Roller, Guide, Models G & H	42	3552	Drive Roller, Front Shaft
	3198	Roller, Guide, Models F & J	47	3520	Cutter Wheel, Rear Shaft
11	3210	Capscrew, Socket Head	<b>Model GS Inset</b>		
<b>Sub-Assemblies</b>			34	3130	Key, Woodruff
12	3700	Head Assembly, Model F	35	3510	Shaft, Rear
	3699	Head Assembly, Model G	37	3499	Shaft, Front
	3702	Head Assembly, Model H	40	5371	Nut, Lock
	3703	Head Assembly, Model J	40A	5372	Nut, Jam
<b>Item 12 includes 13-33 &amp; approp. insets:</b>			43	3551	Drive Roller, Rear Shaft
13	3545	Chime Roller Assembly (Includes Items 7, 7A, 7B, 14, 14A, 14B and 14C)	46	3517	Cutter Wheel, Front Shaft
14	3546 NA	Chime Roller	<b>Model HS Inset</b>		
14A		Cam Pin Assembly	34	3130	Key, Woodruff
14B	3548 NA	Cam Pin	36	3512	Shaft, Rear
14C	3572 NA	Bushing, Chime Roller	37	3499	Shaft, Front
15	3090 A&B	Bearing, Cone and Cup	41	3151	Nut, Lock, Rear Shaft,
16	3100	Gear, Shaft	42	3552	Drive Roller, Front Shaft
16A	3330 NA	Set Screw, Socket Cup Pt	44	5603	Spacer, Rear Shaft
17	3140	Spring	45	3531	Cutter Wheel, Rear Shaft
18	3060	Carrier, Front Shaft	<b>Model JS Inset</b>		
19	5374	Nut, Slotted Hex, Front Shaft	34	3130	Key, Woodruff
19A	8064	Cotter Pin for 5374 Nut	35	3510	Shaft, Rear
20	3120	Ring, Retaining	39	3499	Shaft, Front
21	3056	Body, Housing	40	5371	Nut, Lock
22	3110	Spacer, Rear Shaft	40A	5372	Nut, Jam
23	3180	Sprocket, Driven	42	3552	Drive Roller, Front Shaft
24	3070	Pin, Pivot	48	3532	Cutter Wheel, Rear Shaft
25	8125 & 8126	Serial No. Plate & Caution Plate	<b>Lower Chime Inset</b>		
26	3380	Screw, Phillips Head, 1/4" Self Tapping	54	3619	Lower Chime Roller Adjustment
27	3129	Adjusting Screw Assembly	Lever Assembly		
<b>Note: Item 27 includes Items 28 through 33.</b>			Note: Item 54 includes Items 55 through 65.		
28	3201	Handle	55	3597 NA	Adjustment Lever Rod, Lower Chime
29	3203	Thread Rod	56	5603	Spacer, Flat, 1/2"
30	5313	Nut, Jam, Hex Head	57	3598 NA	Spring
31	5608	Washer, Lock	58	2165 NA	Capscrew, Square Head Cup Pt,
32	6630	Shrink Wrap	59	3097 NA	Bushing, Oilite
33	5603	Washer	60	2119	Capscrew, Hex Head
			61	2147	Capscrew, Flat Head
			62	3592 NA	Roller Shaft, Lower Chime
			63	3591 NA	Roller, Lower Chime
			64	3590 NA	Adjustment Block, Chime Roller
			65	5343	Nut, Hex Head

**Note:** Part numbers marked "NA" are not sold separately

## NOTES

MANUAL AIR UNITS--MODELS FA, GA, HA AND JA

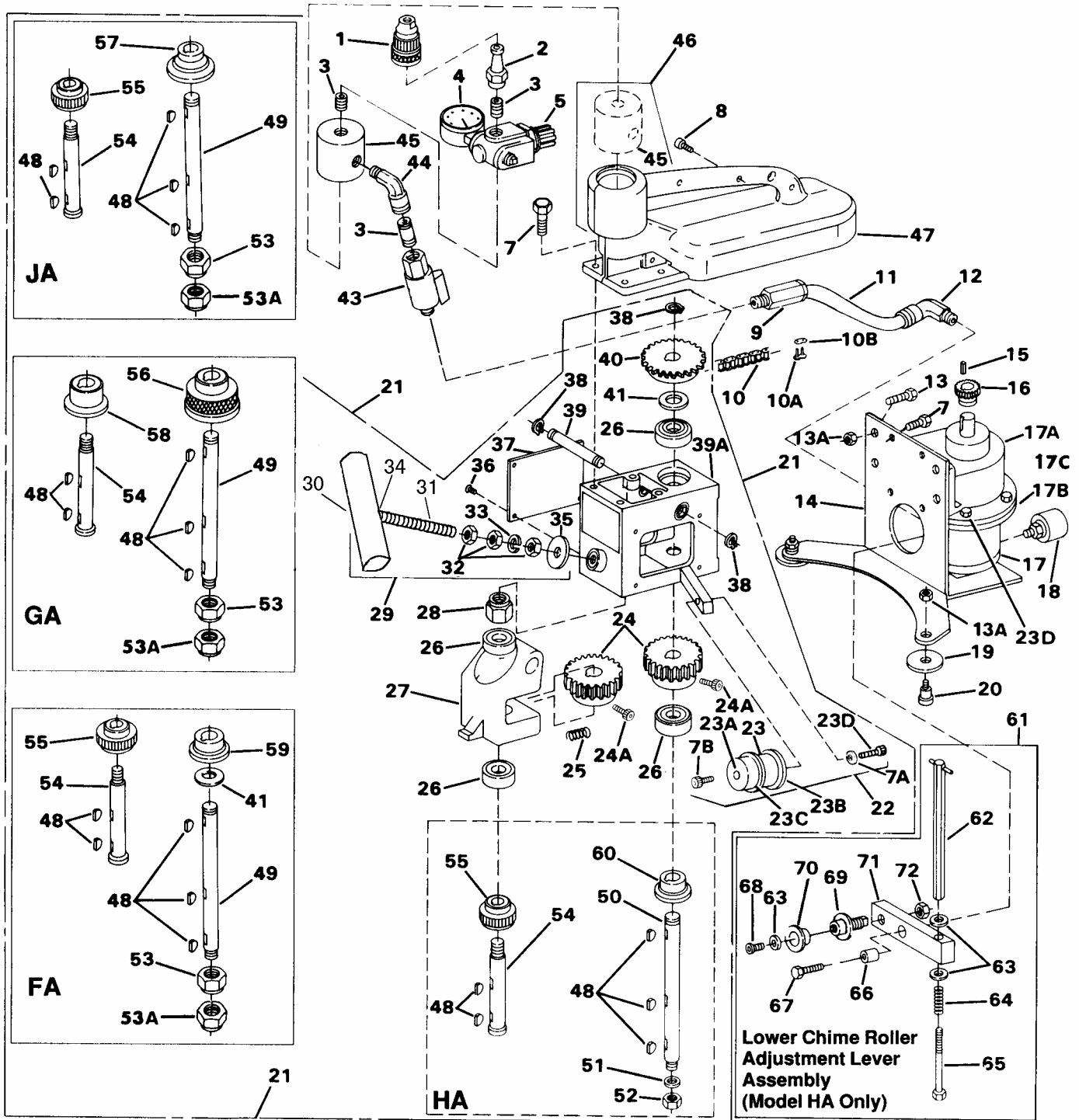



**MANUAL AIR UNITS--MODELS FA, GA, HA AND JA (Sorted by Item Number)**

Item	Part No.	Description	Item	Part No.	Description
	3794	Air Line Assembly (includes <b>Items 3,4,5,9,11,12,42,43 and 44)</b>	28	5374	Nut, Slotted Hex, Front Shaft, 5/8-11
1	3044	Coupling, Quick Disconnect	28A	8064	Cotter Pin for 5374 Nut
2	3045	Adapter, Air Line	29	3129	T-Bar Assembly
3	3807	Nipple, Close, 1/4" NPT, 1" Long		<b>Note: Item 29 includes Items 30 through 35.</b>	
4	11685	Gauge, Pressure, 0-100 PSIG	30	3201	Handle
5	7036	Regulator, 1/4" NPT	31	3203	Thread Rod
7	2106	Capscrew, Hex Head, 5/16-18x3/4	32	5313	Nut, Jam, Hex Head
7A	5606	Washer, Lock	33	5608	Washer, Lock
7B	2112	Capscrew, Hex Head	34	6630	Shrink Wrap
8	2144	Capscrew, Socket Head	35	5603	Washer
9	8502	Connector, Male, 1/4" NPT, 1/2" Hose	36	2222	Screw, Phillips Head, 1/4" Self Tapping
10	3190	Chain, 1.33ST 31 Links	37	8080 & 8125	Side Plate & Serial Plate
10A	3340	Link, Connecting	38	3120	Ring, Retaining
10B	3250	Link, Offset	39	3070	Pin, Pivot
11	8524	Hose, 1/2" Dia. 15" Long	39A	3056	Body, Housing
12	8504	Elbow, 90o, 1/4" NPT, 1/2" Hose	40	3180	Sprocket, Driven
13	2104	Capscrew, Hex Head	41	3110	Spacer, Rear Shaft 1/2" Flat
13A	5237	Nut, Lock, Hex Head	45	3204	Air Line Block
14	3580	Bracket, Motor, Model H	46	3726	Handle Assembly
	3576	Bracket, Motor, Models F, G & J		<b>Note: Item 46 includes Items 1, 2, 3, 45 &amp; 47.</b>	
15	3360	Key, Woodruff, Motor Shaft	47	3023	Handle
16	3171	Sprocket, Drive		<b>Model FA Inset</b>	
17	3011	Motor, Air	41	5603	Spacer, Rear Shaft, 1/2" Flat
17A	3001	Reducer, Gear	48	3130	Key, Woodruff
17B	3761	Flange, Adapter	49	3510	Shaft, Rear
17C	3231	Gear, Pinion	53	5371	Nut, Lock
18	3236	Muffler, Air Motor, 1/4" NPT	53A	5372	Nut, Jam
19	3200	Roller, Guide, Models G & H	54	3499	Shaft, Front
	3198	Roller, Guide, Models F & J	55	3552	Drive Roller, Front Shaft
20	3210	Capscrew, Socket Head	59	3520	Cutter Wheel, Rear Shaft
43	11684	Valve, Ball		<b>Model GA Inset</b>	
44	3815	Elbow, 90o, 1/4" NPT	48	3130	Key, Woodruff
	<b>Sub-Assemblies</b>		49	3510	Shaft, Rear
21	3700	Head Assembly, Model F	53	5371	Nut, Lock
	3699	Head Assembly, Model G	53A	5372	Nut, Jam
	3702	Head Assembly, Model H	54	3499	Shaft, Front
	3703	Head Assembly, Model J	56	3551	Drive Roller, Rear Shaft
	<b>Item 21 includes Items 22-41 &amp; approp. insets.</b>		58	3517	Cutter Wheel, Front Shaft
22	3545	Chime Roller Assembly (Includes Items 7A, 7B, 23, 23A, 23B, 23C, and 23D)		<b>Model HA Inset</b>	
23	3546 NA	Chime Roller	48	3130	Key, Woodruff
23A	3548 NA	Cam Pin	50	3512	Shaft, Rear
23B	3572 NA	Bushing, Chime Roller	51	5603	Spacer, Rear Shaft
23C		Cam Pin Assembly	52	3151	Nut, Lock, Rear Shaft,
23D	2110	Capscrew, Hex Head	54	3499	Shaft, Front
24	3100	Gear, Shaft	55	3552	Drive, Roller, Front Shaft
24A	3330	Set Screw,	60	3531	Cutter Wheel, Rear Shaft
25	3140	Spring		<b>Model JA Inset</b>	
26	3090 A&B	Bearing, Cone and Cup	48	3130	Key, Woodruff
27	3060	Carrier, Front Shaft	49	3510	Shaft, Rear
			53	5371	Nut, Lock
			53A	5372	Nut, Jam
			54	3499	Shaft, Front
			55	3552	Drive Roller, Front Shaft
			57	3532	Cutter, Wheel, Rear Shaft

**MANUAL AIR UNITS--MODELS FA, GA, HA AND JA (Sorted by Item Number) (Cont.)**

<b>Item</b>	<b>Part Number</b>	<b>Description</b>
		<b>Lower Chime Inset</b>
61	3619	Lower Chime Roller Adjustment Lever Assembly
		Note: Item 61 includes Items 62 through 72.
62	3597 NA	Adjustment Lever Rod, Lower Chime
63	5603	Spacer, Flat
64	3598 NA	Spring
65	2165 NA	Capscrew, Square Head Cup
66	3097 NA	Bushing, Oilite
67	2119	Capscrew, Hex Head
68	2147	Capscrew, Flat Head
69	3592 NA	Roller Shaft, Lower Chime
70	3591 NA	Roller, Lower Chime
71	3590 NA	Adjustment Block, Chime Roller
72	5343	Nut, Hex Head

**Note:** Part numbers marked "NA" are not sold separately.

**NOTES**

**AUTOMATIC AIR UNITS--MODELS RFA, RGA AND RJA**

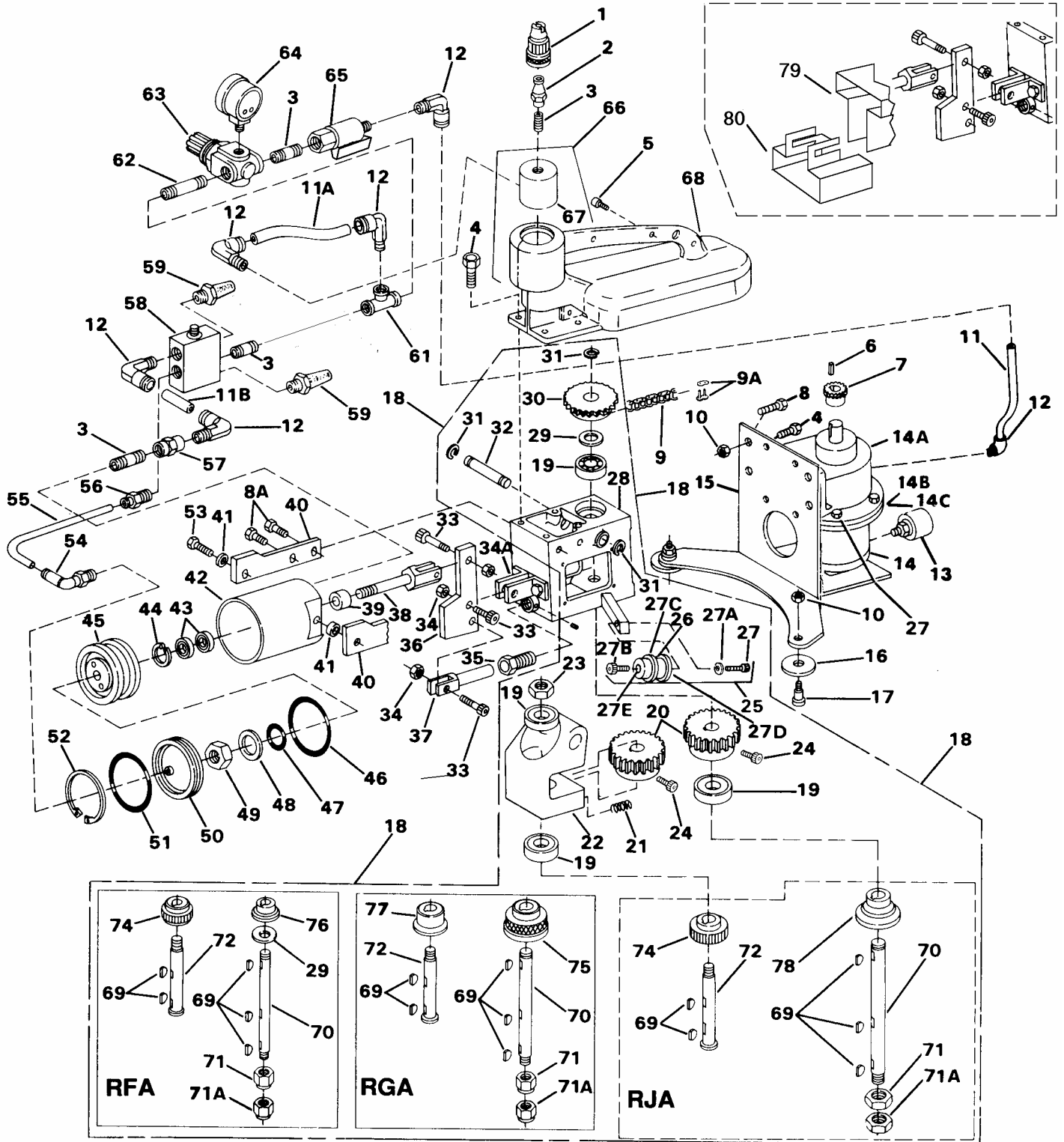

**AUTOMATIC AIR UNITS--MODELS RFA, RGA AND RJA (Sorted by Item Number)**

Item	Part No.	Description	Item	Part No.	Description
	11683	Air Line Assembly (Includes Items 3, 11, 11A, 11B, 12, 54, 55, 56, 57, 58, 59, 60, 61, 62, 63, 64 and 65)	49	5345	Nut, Jam, 7/16-14
1	3044	Coupling, Quick Disconnect	50	3124	Cap, Cylinder, Double Acting
2	3045	Adapter, Air Line	51	6087	O-Ring, Piston Rod
3	3807	Nipple	52	3126	Ring, Retaining, Beveled
4	2106	Capscrew, Hex Head	53	2159	Capscrew, Socket Head,
5	2144	Capscrew, Socket Head	54	8527	Elbow, Swivel, 1/4" NPT, 1/4" Hose
6	3360	Key, Woodruff, Motor Shaft	55	8523	Hose, 1/4" Dia, 10" Long
7	3171	Sprocket, Drive	56	8514	Connector, 1/4" NPT, 1/2" Hose
8	2103	Capscrew, Hex Head	58	7037	Switch, Air Flow
8A	2148	Capscrew, Socket Head	59	8533	Muffler
9	3190	Chain, 31 Links	61	3812	Tee, 1/4" NPT
9A	3340	Link, Connecting	62	3803	Nipple
10	5237	Nut, Lock, Hex Head	63	7036	Regulator, 1/4" NPT
11	3257	Hose, 1/2" Dia, 9-12" Long	64	11685	Gauge, Pressure, 0-100 PSIG
11A	3259	Hose, 1/2" Dia, 4" Long	65	11684	Valve, Ball
11B	3260	Hose, 1/2" Dia, 2-3/4" Long			<b>Sub-Assemblies</b>
12	8504	Fitting, Elbow, 90o, 1/4" NPT, 1/2" Hose	18	3698	Head Assembly, Model RGA
13	3236	Muffler, Air Motor		3704	Head Assembly, Model RFA
14	3011	Motor, Air		3707	Head Assembly, Model RJA
14A	3001	Reducer, Gear			<b>Item 18 includes Items 19-32 &amp; Approp. Insets.</b>
14B	3231	Pinion, Gear	19	3090 A&B	Bearing
14C	3761	Flange, Adapter	20	3100	Gear, Shaft
15	3576	Bracket, Motor	21	3140	Spring
16	3200	Roller, Guide, Model RGA	22	3063	Carrier, Front Shaft
	3198	Roller, Guide, Models RFA & RJA	23	5374	Nut, Slotted Hex, Front Shaft,
17	3210	Capscrew, Socket Head,	23A	8064	Cotter Pin for 5374 Nut
30	3180	Sprocket, Driven	24	3330	Set Screw, Socket Cup Pt,
33	2166	Capscrew, Socket Head,	25	3545	Chime Roller Assembly (Includes Items 26, 27, 27A, 27B, 27C, 27D and 27E)
34	5346	Nut, Lock,	26	3546 NA	Chime Roller
34A	3114	Bracket, Fulcrum Support	27	2110	Capscrew, Hex Head,
35	3111	Guide, Pressure Rod	27A	5606	Washer, Lock
36	3099	Lever, Leverage	27B	2112	Capscrew, Hex Head
37	3112	Rod, Pressure, 2-1/8" RGA/RFA	27C		Cam Pin Assembly
37A	3123	Rod, Pressure, 2" (RJA)	27D	3572 NA	Bushing, Chime Roller
38	3115	Connector, Piston Rod	27E	3548 NA	Cam Pin
39	3097	Bushing, Oilite	28	3059	Body, Housing
40	3117	Support, Air Cylinder	29	3110	Spacer, Rear Shaft, 1/2" Flat
41	3116	Bushing, Pivot	30	3180	Sprocket, Driven
	3134	Cylinder Assembly	31	3120	Ring, Retaining
		<b>Note: #3134 includes Items 42 through 52</b>	32	3070	Pin, Pivot
42	3133	Cylinder	66	3726	Handle Assembly
43	6301	Seals, Air Cylinder, Bal			<b>Note: Item 66 includes Items 1, 2, 3, 67 and 68.</b>
44	8007	Ring, Bal Seal Retaining	67	3204	Block, Air Line
45	3118	Piston, Air Cylinder	68	3023	Handle
47	6088	O-Ring, Cylinder Cap			
47	6089	O-Ring, Piston			
48	5631	Washer, Flat, 7/16"			

**Note:** Part numbers marked "NA" are not sold separately.

**AUTOMATIC AIR UNITS—MODELS RFA, RGA AND RJA (Sorted by Item Number) (Cont.)**

**Model RFA Inset**

29	3110	Spacer, Rear Shaft, ½" Flat
69	3130	Key, Woodruff
70	3510	Shaft, Rear
71	5371	Nut, Lock ¾-10
71A	5372	Nut, Jam ¾-10
72	3499	Shaft, Front
74	3552	Drive Roller, Front Shaft
76	3520	Cutter Wheel, Rear Shaft

**Model RGA Inset**

69	3130	Key, Woodruff
70	3510	Shaft, Rear
71	5371	Nut, Lock ¾-10
71A	5372	Nut, Jam ¾-10
72	3499	Shaft, Front
75	3551	Drive Roller, Rear Shaft
77	3517	Cutter Wheel, Front Shaft

**Model RJA Inset**

69	3130	Key, Woodruff
70	3510	Shaft, Rear
71	5371	Nut, Lock ¾-10
71A	5372	Nut, Jam ¾-10
72	3499	Shaft, Front
74	3552	Drive Roller, Front Shaft
78	3532	Cutter Wheel, Rear Shaft
79	11686	Upper Linkage Guard
80	11687	Lower Linkage Guard

**Note:** Part numbers marked "NA" are not sold separately.

## NOTES

## **SECTION 12 -- GLOSSARY**

The following terms are used often in describing the use of the WIZARD in deheading steel drums. A proper understanding of these terms will help you use your deheader.

**BUNG** -- Fittings located on drum lid. On chemical or oil drums, two bungs, usually 3/4" and 2" (19 and 51 mm) diameter are located near edge of the drum. Bungs will interfere with the drive roller or the cutter wheel unless they are hammered down.

**CHIME** -- The rolled edge of the top and bottom of the drum. Most industrial drums have a flat seam (double seam) comprised of 5 layers of metal. Aseptic food drums have a round seam (triple seam) comprised of 7 layers of metal.

**CUTTING DEPTH** -- How deep the cutter wheel penetrates the drum metal. Proper cutting technique requires that cutting depth be set to cut through only one layer of metal.

**DRIVING UNIT** -- The electric or air motor that powers the propelling action of the opener. Drive unit is considered to be at the rear of the opener. (See illustration below.)

**SHAFT, REAR** -- Shaft closest to the drive unit is defined as the rear shaft. (See illustration below.)

**SHAFT, FRONT** -- Shaft farthest from the drive unit is defined as the front shaft. (See illustration below.)

**HEAD ASSEMBLY** -- The housing body that contains the heart of the WIZARD. This assembly contains gearing, bearings, drive roller, cutter wheel, shafts, adjusting screw and other parts intrinsic to the cutting action of the deheader.

**HOUSING BODY** -- Hollow rectangular casting that encases the rear shaft and the front shaft carrier assembly. (See illustration below.)

**DRUM SHELL** -- The steel body of the drum usually made from 18 or 20 gauge steel.

**U.S.D.A.** -- United States Department of Agriculture. The WIZARD Models F and H have been approved for use in meat and poultry plants operating under Federal inspection.

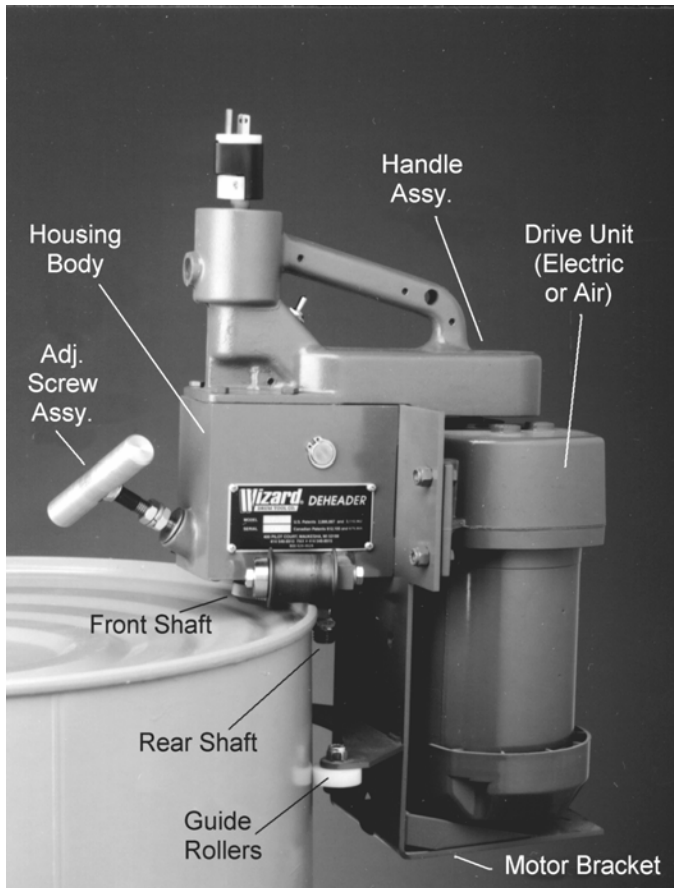

### Limited Warranty

Wizard Drum Tool Company guarantees the materials, components and workmanship in its drum tool products to be of the highest quality and to be free from defects in material and workmanship for a period of one year from the delivery date. Any defective component or parts will be exchanged at our factory with replacement parts, shipped to you prepaid, if found to be defective from other than overload, abuse, careless or negligent use, or failure to maintain the unit as recommended by company operating and service manuals. The company's liability does not extend to damage or malfunction resulting from alterations from original design of the equipment or failure to follow normal operating procedures.

There are no warranties, either express or implied, of fitness for a particular purpose which shall extend beyond the warranty period of one (1) year from date of delivery. No responsibility is assumed from any incidental or consequential damages except for those allowed under state law.

The company reserves the right under its product improvement policy to change construction or design details and furnish equipment when so modified without reference to illustrations or specifications.